

# HF2-50WBC-01 A

## ELECTROMAGNETIC ACTUATOR

### CONTENT

1. SPECIFICATIONS
2. DRAWING
3. TEST METHOD
4. RELIABILITY TEST
5. PACKING
6. HISTORY CHANGE RECORD

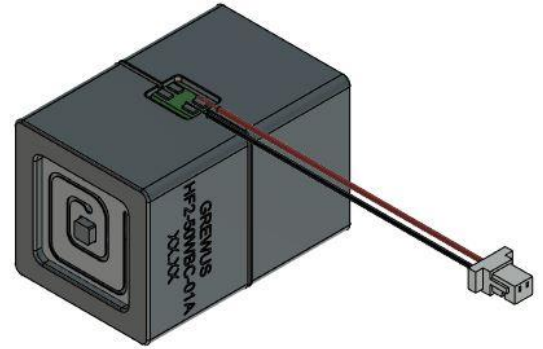

## 1. SPECIFICATIONS

Parameter	Unit	Conditions / Description	MIN	TYP	MAX
Rated Voltage	V(rms)			1.0	
Nominal Coil Resistance	Ohm		4.5	5.0	5.5
Acceleration	G <sub>0-p</sub>	At rated voltage at resonance frequency, 200gr attached mass, at 22-24°C, 40-60%RH (see test method 3.2.1)		0.7	
Resonance Frequency	Hz	At 22-24°C, 40-60%RH (see test method 3.2.2)	47.5	50.0	52.5
Resonance Frequency	Hz	From 0°C to +40°C (see test method 3.2.2)	46.0	50.0	54.0
Transient Voltage Max	V <sub>p-p</sub>	≥0,2kg attached mass		5.0	
Operating Temperature	C°		-20		+60
Storage Temperature	C°		-30		+70
Operating Humidity	RH%		+10		+90
Storage Humidity	RH%		+5		+95
Weight	g			22	

Remark:

DESIGNED BY	Christopher Pagel	DATE	2023.09.22	PART NO.	HF2-50WBC-01 A	INDEX	A
RELEASED BY	Anouschka Esselun	DATE	2023.09.22				
CHANGED BY	Rabea Richter	DATE	2024.03.04				
DRAWING NO.	449674680						

## HF2-50WBC-01 A

ELECTROMAGNETIC ACTUATOR

### 2. DRAWING

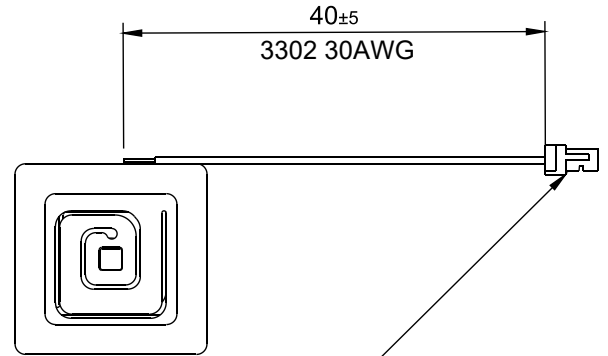
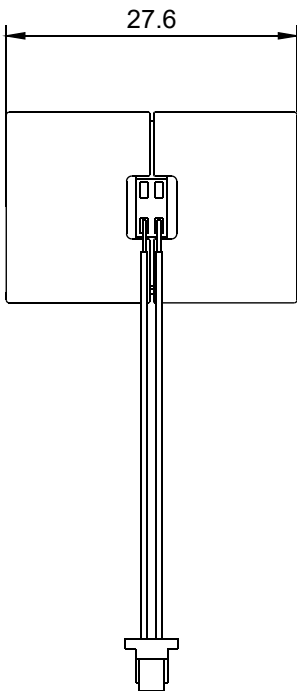
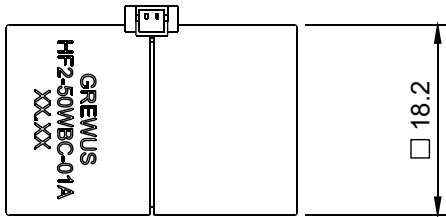

SHR-02V-S-B / similarly

Black Wire Pin1  
Red Wire Pin2

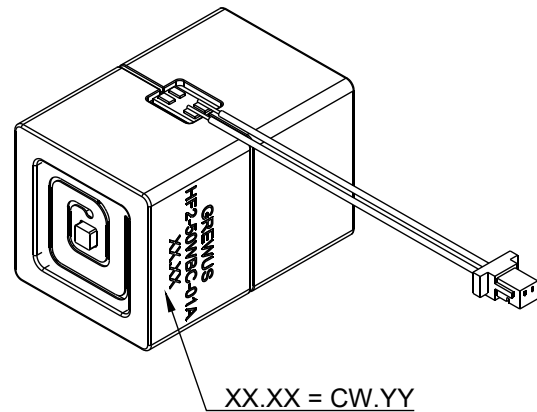

Tolerance: ±0.3mm

DESIGNED BY	Christopher Pagel	DATE	2023.09.22	PART NO.	HF2-50WBC-01 A	INDEX
RELEASED BY	Anouschka Esselun	DATE	2023.09.22			
CHANGED BY	Rabea Richter	DATE	2024.03.04			
DRAWING NO.	449674680					A

# HF2-50WBC-01 A

ELECTROMAGNETIC ACTUATOR

## 3. TEST METHOD

### 3.1 TEST EQUIPMENT

Function	Manufacturer	Model Number
<b>Acceleration Measurement</b>		
Function Generator	Rigol	DG2052
Power Amplifier	Toellner	TOE7608
Interface	NI	USB-4431
Accelerometer	PCB Piezotronics	352C33
<b>Electrical Measurement</b>		
Audio Analyzer	NTi Audio	FX100

### 3.2 TEST FIXTURE

#### 3.2.1 ACCELERATION MEASUREMENT

For this test bench, a defined load (30g to 200g weight) is centric suspended at its four edges inside a heavy metal frame (1mx1m). The suspension is made by 4 thin threads, with a spring inserted at the top. The actuator and the accelerometer are mounted stiffly on the load.

#### 3.2.2 ELECTRICAL MEASUREMENT

Electrical impedance response has been measured with infinite mass mounted to the actuator.

DESIGNED BY	Christopher Pagel	DATE	2023.09.22	PART NO.	HF2-50WBC-01 A	INDEX	A
RELEASED BY	Anouschka Esselun	DATE	2023.09.22				
CHANGED BY	Rabea Richter	DATE	2024.03.04				
DRAWING NO.	449674680						

### 3.3 MEASUREMENT CURVES (only for reference)

#### 3.3.1 ACCELERATION CURVE

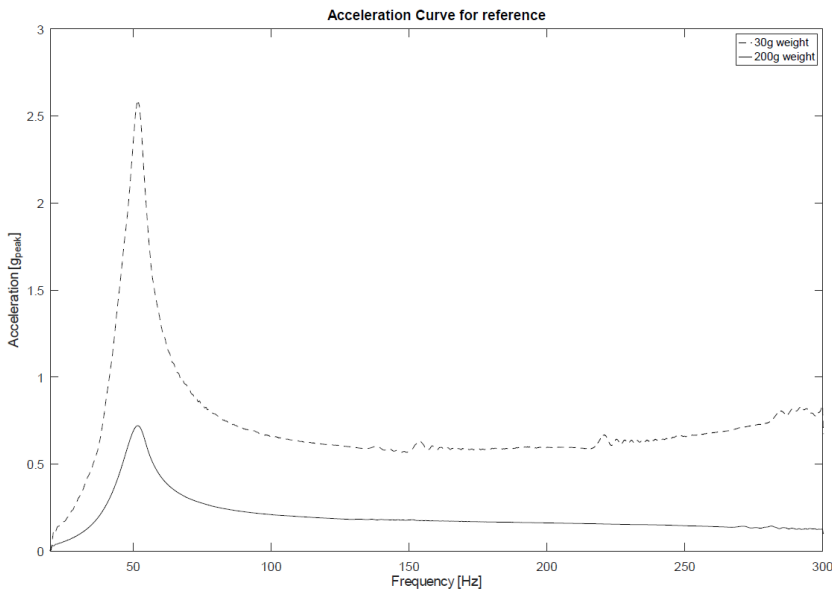

#### 3.3.2 IMPEDANCE CURVE

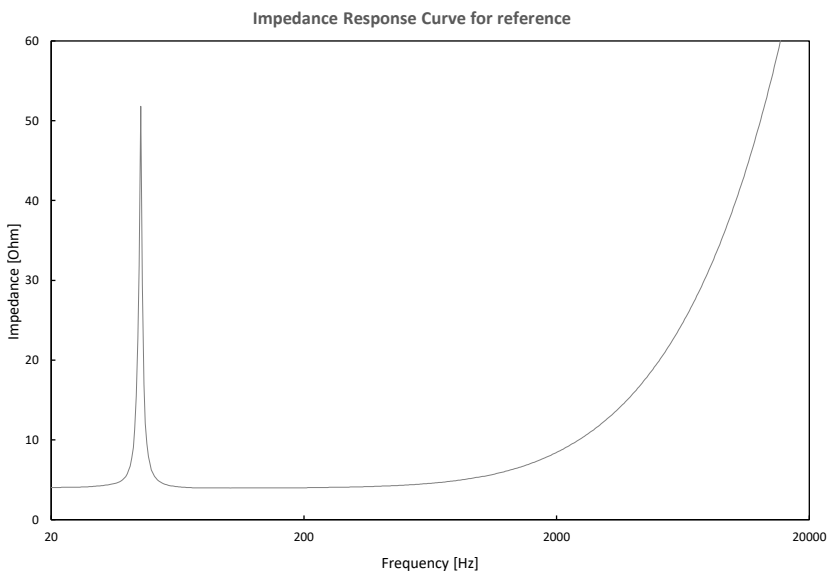



DESIGNED BY	Christopher Pagel	DATE	2023.09.22	PART NO.	HF2-50WBC-01 A	INDEX
RELEASED BY	Anouschka Esselun	DATE	2023.09.22			A
CHANGED BY	Rabea Richter	DATE	2024.03.04			
DRAWING NO.	449674680					

# HF2-50WBC-01 A

## ELECTROMAGNETIC ACTUATOR

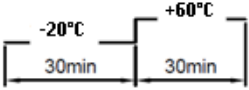
### 4. RELIABILITY TEST

Test Name	Test Description	Success Criteria
Life Test	1Vrms, 50Hz Duration 240hours, Cycles 10x0.5s ON/0.5s OFF to 10x1s ON/0.5s OFF to 5s on/2s OFF	Meet specification within 80% of initial value after 4 hours at room temperature.
Temperature Cycle Test	-20±2°C, 30min. +60±2°C, 30min. 1H/Cycle, Cycles 240 	Meet specification within 80% of initial value after 4 hours at room temperature.
Short Term Life Test	1Vrms, 50Hz 80°C/40%RH, 6hours (0.5s ON/0.5s OFF )	Meet specification within 80% of initial value after 4 hours at room temperature.
High Temperature Test	+70±2°C 85%RH 168 hours	Meet specification within 80% of initial value after 4 hours at room temperature.
Low Temperature Test	-30±2°C 168 hours	Meet specification within 80% of initial value after 4 hours at room temperature.
Humidity Cycle Life Test	1Vrms, 50Hz (10X0.5s ON/0.5s OFF to 10X1s ON/0.5s OFF to 5s ON/2s OFF) , +25°C/90%RH (5.5h) +50°C/30%RH (5.5h) 12h/Cycle, Cycles 4 	Meet specification within 80% of initial value after 4 hours at room temperature.
Drop Test	1.5m to concrete /in specified drop buck onto 6 face planes and 4 corners 2 times	Meet specification within 80% of initial value after 4 hours at room temperature.

DESIGNED BY	Christopher Pagel	DATE	2023.09.22	PART NO.	HF2-50WBC-01 A	INDEX
RELEASED BY	Anouschka Esselun	DATE	2023.09.22			
CHANGED BY	Rabea Richter	DATE	2024.03.04			
DRAWING NO.	449674680					A

# HF2-50WBC-01 A

ELECTROMAGNETIC ACTUATOR

## 5. PACKING

### 5.1 PACKING QUANTITY

54pcs per tray  
 6 trays per carton  
 324 pcs per carton in total  
 Carton size: 25x35x19cm

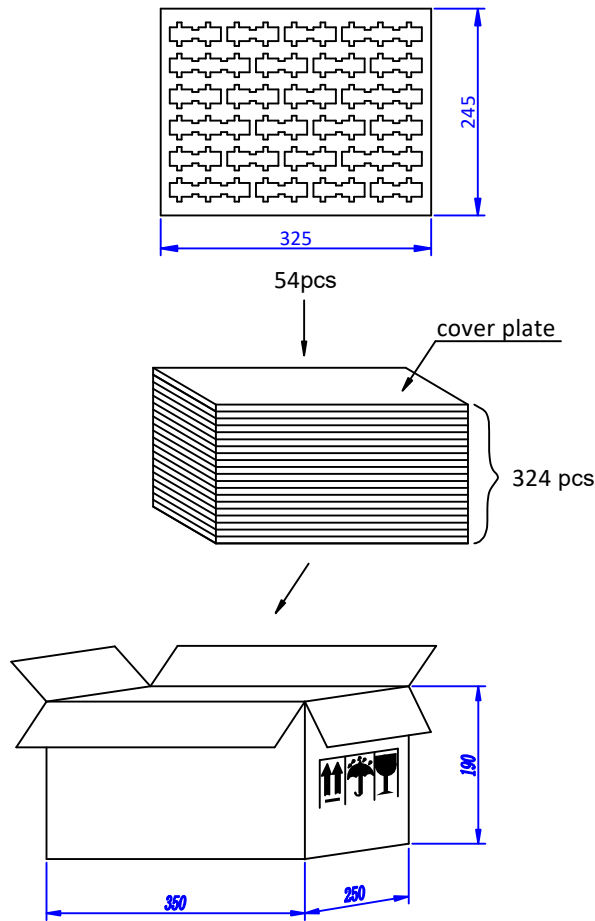

## 6. HISTORY CHANGE RECORD

REV	CHANGE ITEMS		DATE
	BEFORE CHANGE	AFTER CHANGE	
A0_pre		Initial preliminary version	2023.09.22
A1_pre	Humidity Cycle Life Test graph shows 0°C 90%RH	Change to 25°C 90%RH	2023.11.14
A2_pre	Added resonance frequency measurement conditions to page 1		2024.01.16
A0	Preliminary part name: HF2BC-01A	Final part name: HF2-50WBC-01A	2024.03.04
A1		Update product picture, add tolerance to wire length: 40mm ±5mm	2024.03.06

DESIGNED BY	Christopher Pagel	DATE	2023.09.22	PART NO. <b>HF2-50WBC-01 A</b>	INDEX <b>A</b>
RELEASED BY	Anouschka Esselun	DATE	2023.09.22		
CHANGED BY	Rabea Richter	DATE	2024.03.04		
DRAWING NO.	449674680				